

Jacuzzi® Massage Chairs

JPro302XR™

Massage Chair User Manual



Please read SAFETY INSTRUCTIONS carefully before using the JPro302XR™

Key Features

1. Exhibits patented 2D massage rollers that glide seamlessly, navigating upward and downward motions, as well as moving gracefully from side to side, ensuring a thoroughly soothing massage experience for your back muscles.
2. Includes ShapeSense™ to detect the shape and size of your body for a customized massage experience.
3. Converts into GravityFree™ position with 1-button touch, which moves your feet above your head, allowing your body weight to be more evenly distributed, providing the ultimate in relaxation.
4. The Jacuzzi® Massage Chair slides forward in the frame with CompactGlide™ before reclining, which requires only 3(three) inches of clearance behind the massage chair.
5. CalfRelief™ delivers an air pressure massage to tired calf muscles and SoleRefresh™, provides an energizing and kneading massage that targets the nerve endings at the bottom of your feet.
6. HipSculpt™ provides an air compression massage that targets the waist, thighs and glutes.
7. PalmSoothe™ provides an air pressure massage from your fingertips to your elbow; targeting areas prone to carpal tunnel and arthritis.
8. LegExtender™ Pro extends legrest up to 9(nine) inches offering optimal comfort even for taller users.
9. Includes convenient full-color LCD remote control for ease of use.
10. FlexRelief™ relieves pressure in your spine and joints.

Note:

Jacuzzi® Massage Chairs and their partners may make product modifications and enhancements. Specifications may change without notice. International products may be configured differently to meet local electrical requirements. Dimensions are approximate. Manufactured under one or more United States patent numbers Other patents may apply.

Table of Contents



Reference	Safety Precautions 1 External Structure Parts 3 Internal Structure Parts 4 Mechanical Components Diagram 5 Mechanical Components List 6
Setup	Installation 7 Before Massage Operation 11
Massage Chair Operation	Remote Control 13 Operating Instructions 17 Massage Chair Functions 18 Powering Down 19
Maintenance	Cleaning the Massage Chair 20
Additional Information	Troubleshooting 21 Technical data 22 Warranty Back Cover

Thank you for choosing Jacuzzi® JPro302XR™.
 Please read this manual carefully before using the massage chair.
 Please keep this manual in a safe place for future reference.

1 Safety Precautions

Reference

- Please read this manual carefully to make sure the installation and operation of the Jacuzzi® Massage Chair is correct.
- Safety Precautions, which include both warnings and cautions, are important for your safety. Please read before operating the massage chair.

 Warning	This sign indicates warning of causing injury or death.
 Caution	This sign indicates caution of causing possible injuries or damages.

Warning

This product may not be suitable for users who experience increased discomfort, risk of accident, or bodily harm. Users with the following conditions should consult their doctor before use.

- Osteoporosis, vertebral fractures, and acute painful diseases such as sprains or muscle strains.
- Pacemakers or other implanted medical devices - The vibrations and electromagnetic fields from massage chairs could interfere with medical devices.
- Cancer - Massaging directly over tumors is not recommended. Check with a doctor first.
- Perceptual disorders due to high levels of peripheral circulatory disturbances such as diabetes.
- Protruded invertebrate discs.
- Pregnant women and those who have recently given birth, as well as people with poor health.
- Sensitivities or allergies to heat.
- Users that have been diagnosed with narcolepsy.
- Sensory loss - Those with reduced sensation may not realize if the massage pressure is uncomfortably high.
- Those under the influence of drugs, alcohol or medication that causes drowsiness - Impaired users have a greater risk of falls or improper use.
- Children under the age of 14 - Massage chairs are designed for adults and can overextend children's muscles and joints.

Grounding instructions

The massage chair is equipped with a cord that has a grounding conductor. The plug must be plugged into an appropriate socket that is properly installed and matched with the plug. Always use a surge protector.

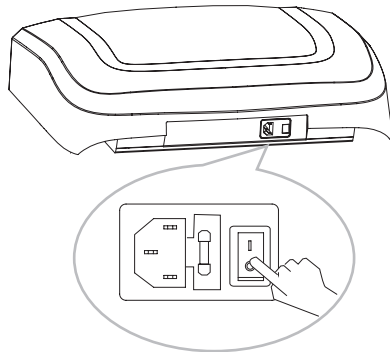

Replacing the fuse

If the fuse is burned out, turn off the on/off switch and unplug the power from the wall outlet. Open the lid covering the fuse which is located in the switch box. Make sure the replacement fuse is the same size as the current burnt out fuse. Contact an electrician if you need assistance.

Safety Precautions

Reference

Warning

Accident or Injury

- Before operating the Jacuzzi® Massage Chair, please make sure to check the area around the massage chair for any obstructions.
- When using the backrest, calf up & down, or calf extend, be sure to check that there is no interference or objects in the area (behind, under, or in front of the massage chair).
- In the event of a physical abnormality or abnormality in use, stop using the massage chair immediately and ask a doctor.
- Use caution when massaging around sensitive areas like the head and neck. Pay close attention to the movement of the massage rollers and avoid over-massaging or applying too much pressure.
- DO NOT massage the abdomen or knees with this machine.
- If you want to leave your seat during the massage, you must stop the massage chair before you leave the seat.
- DO NOT use the massage chair with other instruments.
- DO NOT allow children or pets to play on or around the massage chair (especially while in use.)
- DO NOT sit or stand on the backrest, armrests or legrests.
- Users requiring assistance should be accompanied by a parent, guardian, or aide for safety.
- Before moving the massage chair, the backrest and legrest must be angled back to their original position.
- DO NOT fold cushions for storage.
- DO NOT operate the massage chair without the user properly seated and positioned in the massage chair.
- DO NOT fall asleep in the massage chair.

Fire and Electric Shock

- When assembling, make sure the massage chair is unplugged and the power is off.
- Insert the electrical plug from the massage chair into a compatible power outlet. Make sure the plug is completely inserted into the socket to reduce short circuit or fire risk.
- Always unplug the power cord when not in use. Be sure to turn off all massage chair functions by pressing the on/off switch first before unplugging.
- Power cord, plug, and socket can't be used in broken or loose contact condition.
- DO NOT use other electric power except rated voltage in case of fire, electric shock or any breakdown.
- DO NOT use power cord or operate the massage chair if the cord or plug has been damaged, frayed, knotted, twisted or crushed.
- DO NOT use if the massage chair is wet or if the user is wet.
- DO NOT use the massage chair outdoors.
- DO NOT use the massage chair in areas where the humidity is high such as a sauna or steam room.
- Keep the power cord away from heated surfaces.
- Never plug/unplug the power cord plug socket with wet hands.
- Always unplug the massage chair from the electrical outlet immediately after using and before cleaning. DO NOT leave the chair unattended while plugged in.

Disassembly and Maintenance

- If the massage chair becomes dysfunctional, defective, or wet, contact your authorized retailer or send the massage chair to the assigned service agent. Self-modification, disassembly or maintenance is forbidden.
- If power cord or plug is damaged, please DO NOT replace it yourself, please contact your authorized retailer for replacement.
- To avoid electric shock or bodily harm, please DO NOT open or disassemble any part of the massage chair; there are no user-serviceable parts.
- Check leather or cloth material on the back and other areas to see if they are broken or not. If broken, even if it seems to be a minor issue, please stop using the massage chair, unplug the power and have it repaired.

3 External Structure Parts

Reference

External Structure

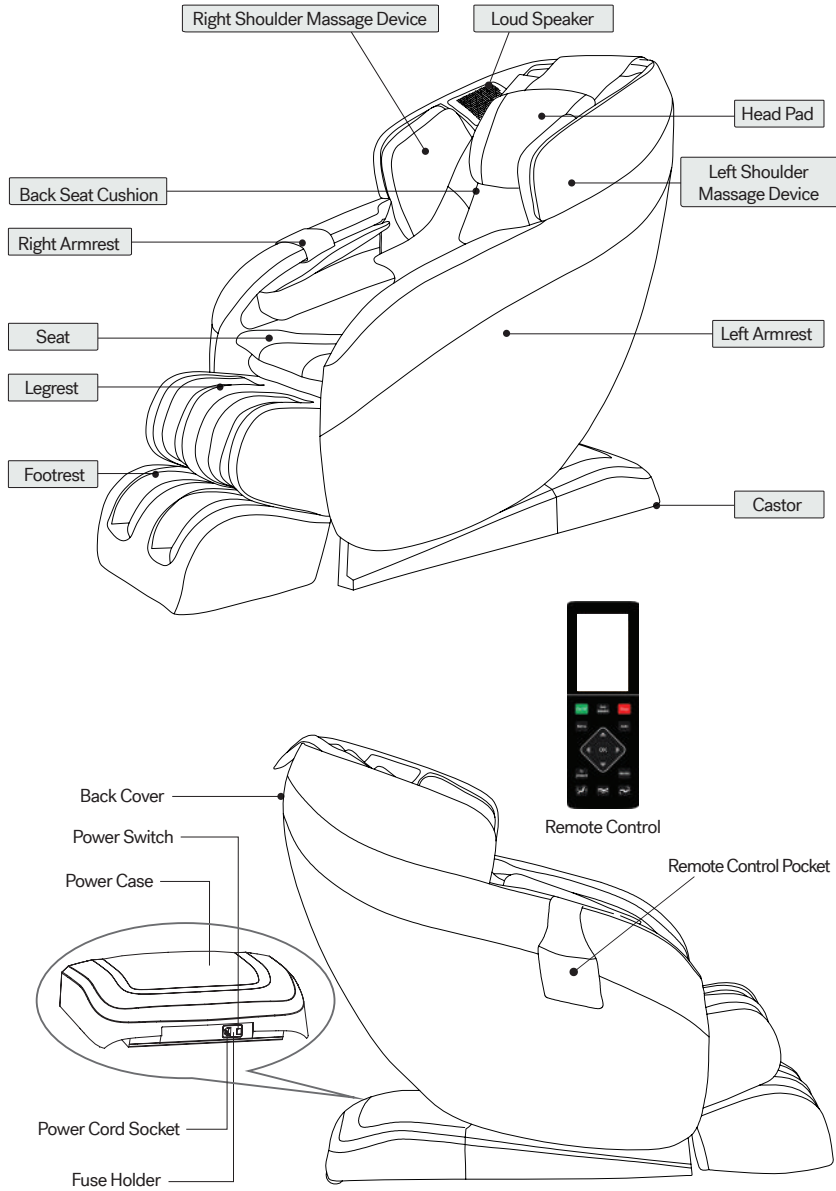

Internal Structure Parts

Reference

4

Internal Structure

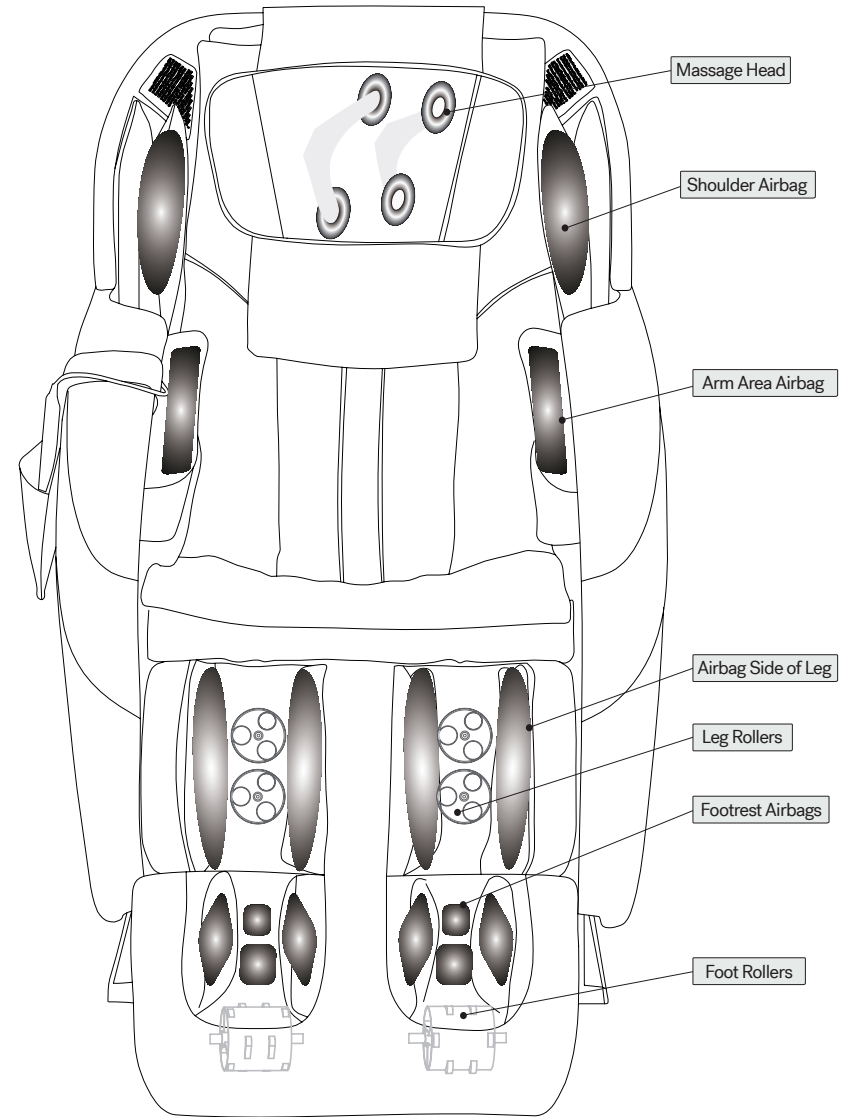

5 Mechanical Components Diagram

Reference

Exploded Diagram

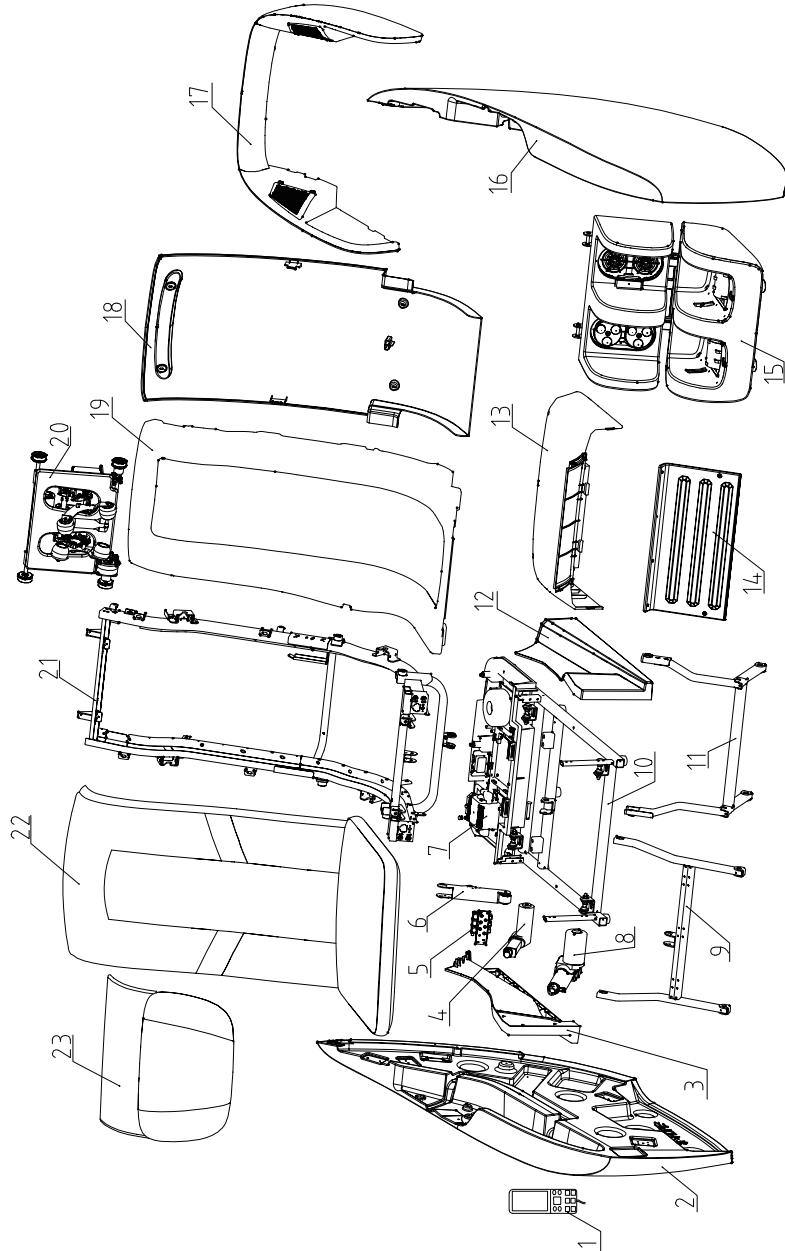

Mechanical Components List

Reference

6

	Part	Quantity
1	Remote Control	1
2	Right Armrest Assembly	1
3	Right Side Fender	1
4	Footrest Electric Actuator	1
5	Solenoid Valve Assembly	1
6	Leg Support Plate	1
7	Power Case Assembly	1
8	Back Electric Actuator	1
9	Front Swing Assembly	1
10	Bottom Frame Assembly	1
11	Back Swing Assembly	1
12	Left Side Fender	1
13	Power Case Assembly	1
14	Front Fender Assembly	1
15	Foot and Leg Assembly	1
16	Left Armrest Assembly	1
17	Shoulder Assembly	1
18	Back Cover Assembly	1
19	Back Cover	1
20	Massage Mechanism	1
21	Back Frame Assembly	1
22	Back Seat Cushion	1
23	Pillow	1

7 Installation (1)

Setup

Scan the QR code to follow along with a video assembly of the JPro302XR™.



Step 1. Remove the massage chair from the box.

1. Remove the accessory box and the legrest from the carton.
2. Remove the main body of the massage chair.
3. Confirm all the accessories are present.

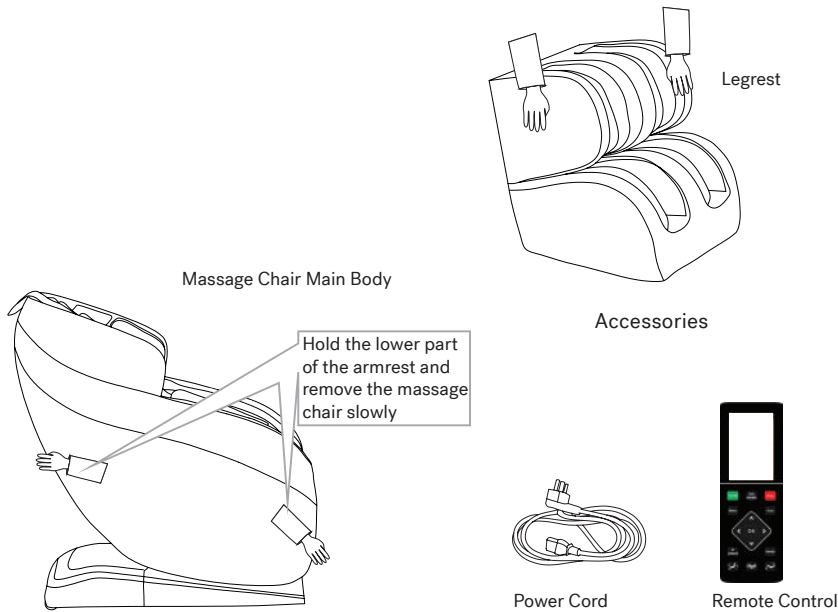

Installation (2)

Setup

8

Step 2. Locate the remote control

1. Remove the remote control bag from the inner arm airbag of the right armrest.
2. Place the remote into the remote control holder.

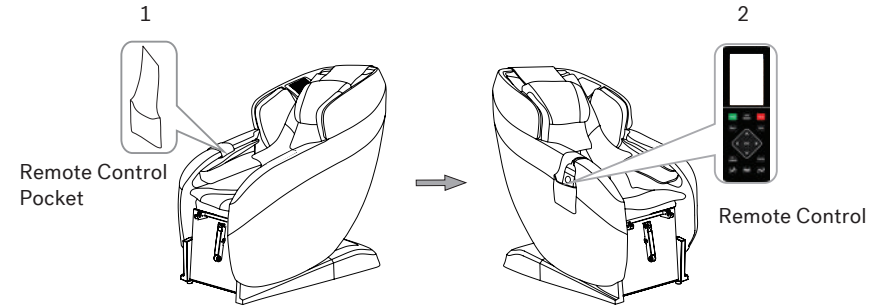

Step 3. Check for adequate space.

Ensure there is enough space behind the massage chair to allow for it to recline.

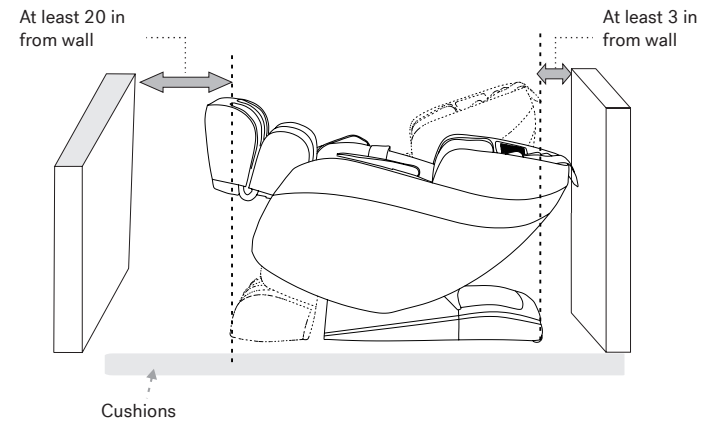

Consider using a rug or floor pad to avoid damage to floor.

9 Installation (3)

Setup

Step 4. Assembling the massage chair.

1. Pair the leg and foot harness plug with the socket on the massage chair.
2. Insert one of the air tubes in the legrest firmly into the air nozzle on the main body.
3. Raise the legrest with both hands and set pins into the hinges on the massage chair.
4. Connect the hook and loop fastening strip on the back of the legrest to the aligned strips on the front of the seat.
5. Connect the hook and loop fastening strip on the top of the legrest with the aligned strip on the front edge of the seat cushion.

! Note: The shaft must be securely attached, otherwise it will fall off. When inserting the air tube and wiring harness, DO NOT wrap the air tube and wiring harness together.

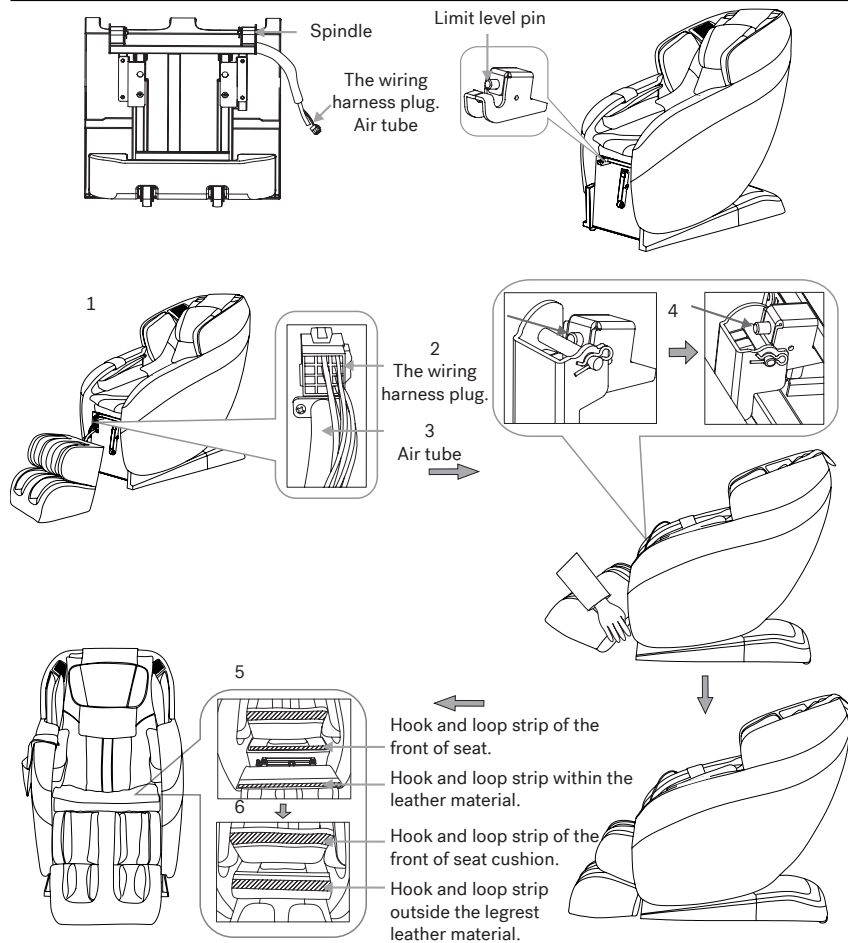

Installation (4)

Setup

10

Step 5. Powering on the massage chair.

1. Plug the power cord in the hole a on the power box as shown in the right picture.
2. Insert the plug end of the power cord into the electrical outlet.
3. Turn on the switch behind the power box. (Switch on/off "O/I", press I down to turn it on.)
4. Use the remote to select a massage program, and enjoy!

! Make sure the switch is off before you insert the plug of power cord into the socket.

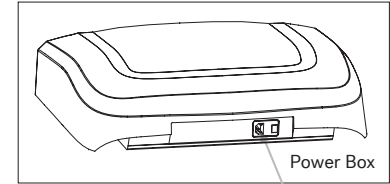

Plug the power cord into the power box.

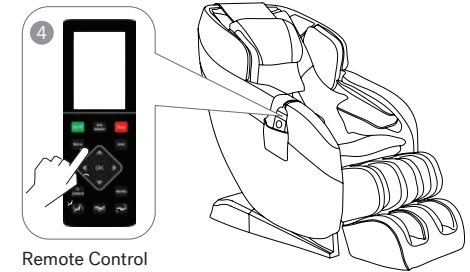
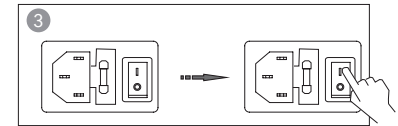
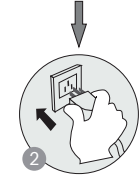
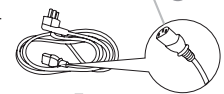

11 Before Massage Operation

Setup

Refer to this page before using your Jacuzzi® Massage Chair.

1. Check space in front

Check the areas when the back and legs extend to make sure there are no obstructions.

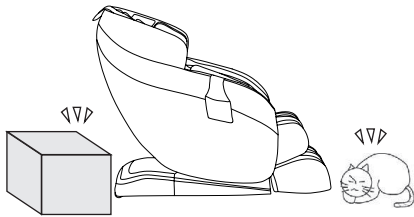

2. Check power cord and plug.

• Ensure plug is clean, dry and free of dust. DO NOT bend or apply pressure to plug.

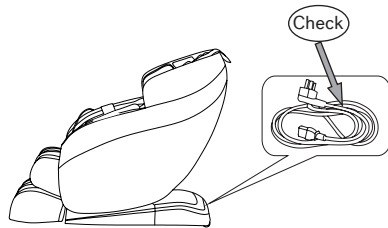

3. Space needed for operation.

• At least 3" inches from the wall behind.

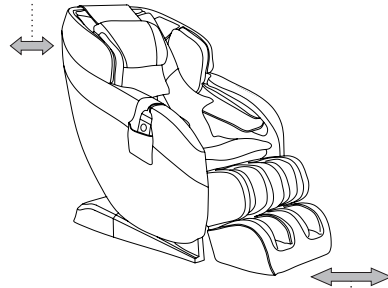

• At least 20" inches in front of the legrest:

4. Check surroundings

• When the backrest or legrest reclines or extends, please make sure to:

1. Check for obstructions in front of and behind the massage chair.
2. Ensure there is 3 in of space behind and 20 in of space in front of the massage chair.

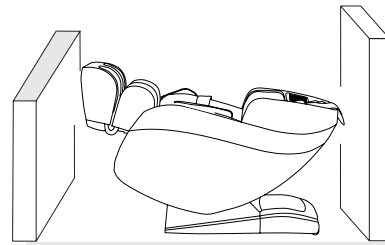
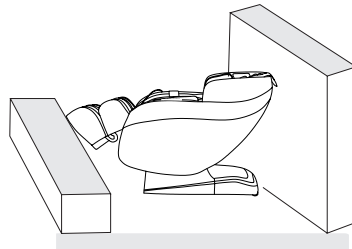

Before Massage Operation

Setup

Moving the massage chair.



Caution
DO NOT move the massage chair when it's working in case of accidents or damage.

Prepare the massage chair

- Bind the cables and put them in the seat to avoid damage when moving.
- Avoid bumping the massage chair with your body or with another object. This could damage the internal mechanisms of the massage chair.
- DO NOT use the castor if the floor is easily damaged. The massage chair will need to be lifted.
- Using your bodyweight, push down on the back of the massage chair in order to raise it onto its castors. Then, slowly guide it to the desired location.



Lean the massage chair back so it's resting on the castors. Push the massage chair on the back castors to the desired destination, then slowly release the massage chair until it's completely resting on the floor.

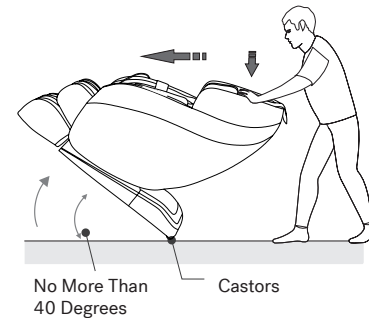

Please hold the footrest to move the massage chair as shown in the picture to prevent any scratches on the leatherette.

Note: the armrest does not move when the back of the massage chair is reclining.

ShapeSense™ Setup

1. Make sure the massage rollers stop in the upper part of the backrest, then sit on the massage chair slowly to avoid injury caused by the massage head being in the wrong position.

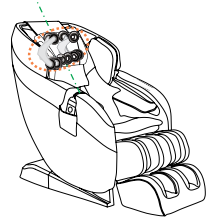

2. When setting up ShapeSense™, if the massage head can not find the shoulder position, it will default to the middle position.

3. Correct position: Your back should rest on the back of the chair, with your head resting on the pillow.







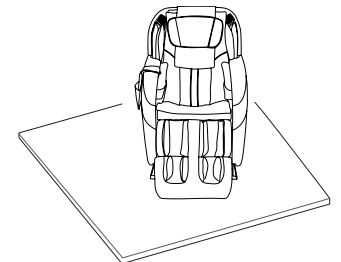

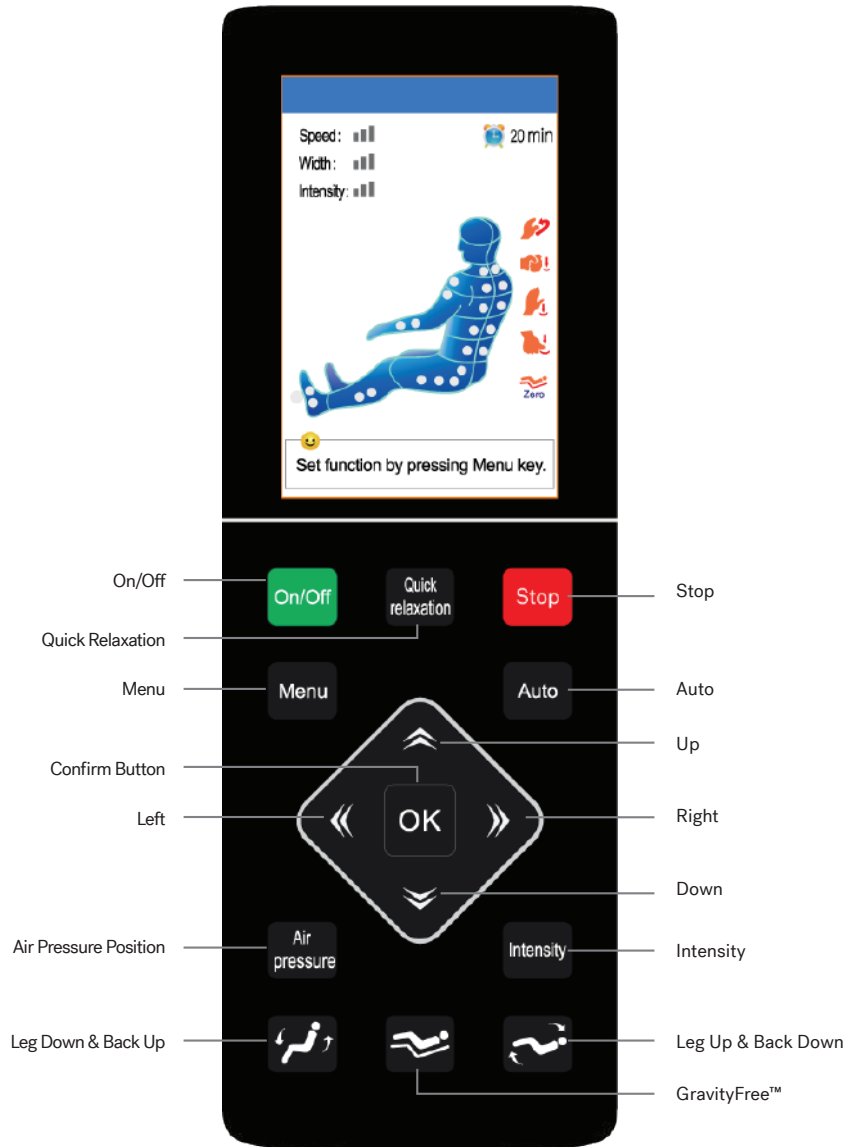

- Sit up straight with good posture to prevent incorrect ShapeSense™ detection which could cause discomfort.
- You will hear a "beep" once ShapeSense™ is complete. If you need further adjustment of rollers, press the up or down key on the remote.

- You can remove the pillow to increase massage pressure.
- Place the massage chair on a rug, blanket, or other soft floor covering to prevent marks or scuffs on floor.



Manual Control



1. In standby mode, press this button to turn the massage chair on. This will bring you to the home screen. From the home screen press this button and the massage chair will go into the shutdown process, the chair will adjust to the original position and reset the functions. The remote control will go off 6 to 10 seconds later.
 - 
2. Press this button to enter the quick relaxation auto program. The timer for this massage is 8 minutes. Press it again to stop the quick relaxation auto program.
 - 
3. Press this button to stop all current massages. This will deactivate the chair and remote. To continue the massage, press the power button to reactivate the massage chair and remote.
 - 
4. Press this button from the home screen to enter the main menu or to return to the home screen from the main menu.
 - 
5. Press this button to turn on or cycle through the auto massages. The screen will display one of six auto massages. The choices are "Recovery", "Pain Relief", "Stretch", "Overall", "Rocking Relax", and "Health Care".
 - 
6. Press this button to turn on or cycle through the air massage features.
 - 
7. Press this button to adjust the intensity of the air massage features. There are three levels of intensity.
 - 
8. The directional pad allows you to navigate through the menu. The up and down buttons navigate up and down the menu options. The left and right buttons enter and exit the sub menus. The up and down buttons are also used to manually adjust the shoulder height during ShapeSense™.
 - 
9. Press this button to confirm selections in the menu.
 - 
10. Press and hold this button to raise the backrest and lower the legrest. Release the button to stop moving.
 - 
11. Press and hold this button to lower the backrest and raise the legrest. Release the button to stop moving.
 - 
12. Press this button to enter the GravityFree™ position. Press it again to return to the default position.
 - 

LCD Display Graphic Description

Home Screen

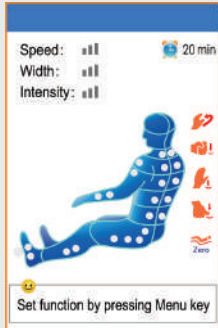

Press the on/off button, and you'll hear one beep. The LCD screen displays the boot-up screen, then it displays the Main Menu and gives the option to enter Standby Mode. The Main Interface shows the massage position, massage mode, time, current massage status etc.

- Massage function
- Kneading
 - Tapping
 - Knocking
 - Shiatsu
 - GravityFree
 - Time Left

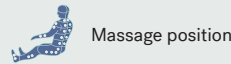

- Massage speed (5 levels)
- Massage width (narrow, mid, wide)
- Massage Intensity (5 levels)

Main Menu



Press the Menu button while on the Home Screen and it will switch to the Main Menu, where the user can set the massage function from available options. Press the Menu button while in the Main Menu and it will exit and return to the Home Screen.

- Auto massage: Press Menu in the Home Screen to enter Auto massage, there are six Auto-Massage methods to choose from: Recovery, Pain Relief, Stretch, Overall, Rock Relax, and Health Care.

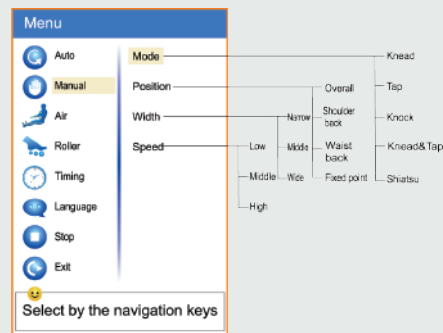

- Mode: Knead, Tap, Knock, Knead&Tap, and Shiatsu.
- Position: Overall, Shoulder Back, Waist Back and Fixed Point.
- Width: Narrow, Middle, and Wide.
- Speed: Low, Middle, and High.

On the Home Screen, use the Up and Down buttons to adjust the massage position. When adjusting, the reminder bar will display the following: "the massage position is adjusting."

LCD Display Graphic Description

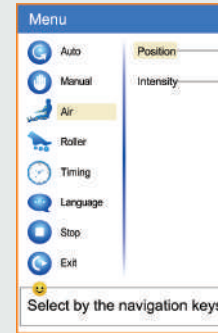

- Air Pressure Massage: After pressing the Menu button, select the Air button and press OK. There are two options from which to choose: Position and Intensity. Press either and press OK to proceed. You can choose Full Body, Upper Body, or Legs & Feet by pressing any of those buttons and then selecting OK. To adjust the intensity of your massage, select Intensity, where it provides 5 levels of intensity from which to choose.

- Foot Roller: Press the Menu button, then select Roller and press OK. You then have the following options: Quick Soft, or Stop.

- Timer: Press the Menu button, then press Timer. You can choose from the following massage durations: 10 minutes, 20 minutes, or 30 minutes. The default time is 20 minutes, after which the massage chair will turn off automatically.

- Setting: Press the Menu button, choose Setting, then use the directional buttons to choose the preferred user language.

- Stop: Press the Menu button, select the Stop button, and it will stop the massage and return to the Main Menu.

- Exit: Press the Menu button and select Exit using the directional buttons. This will return you to the Home Screen.

After turning on the massage chair, it will start ShapeSense™ for the first time, during which there will be a beep every second. The screen will display the following message: please adjust your shoulder height directly. During this time, if you feel the height is not adjusted to your liking, use the Up or Down buttons to make fine-tuned adjustments to match your shoulder position. The default duration is 20 minutes, after which the massage chair automatically shuts down and resets.

to make fine-tuned adjustments to match your shoulder position. The default duration is 20 minutes, after which the massage chair automatically shuts down and resets.



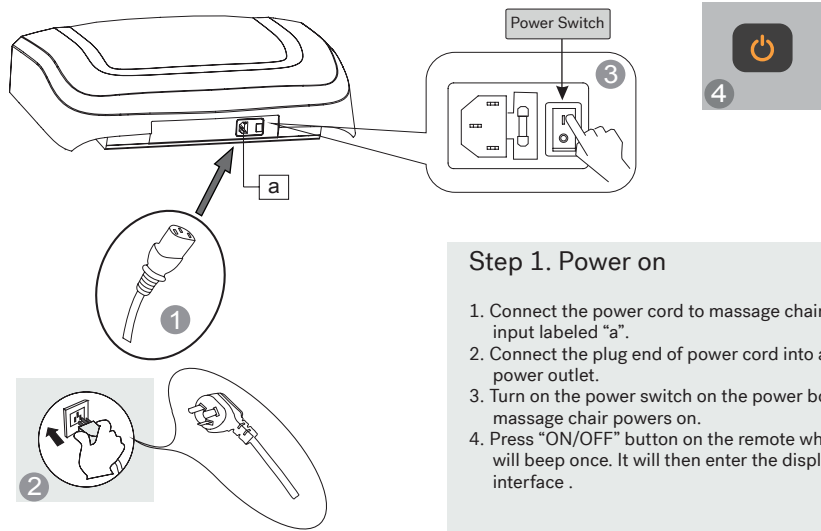

Step 1. Power on

1. Connect the power cord to massage chair input labeled "a".
2. Connect the plug end of power cord into a power outlet.
3. Turn on the power switch on the power box, massage chair powers on.
4. Press "ON/OFF" button on the remote which will beep once. It will then enter the display interface .

Step 2. Massage

1. Operate according to Controller Operation instructions. As for the massage method's details, please refer to remote control's Usage page.
2. When the massage ends, the massage chair will return to the default position, meanwhile "Shutting down" will be displayed on the controller.

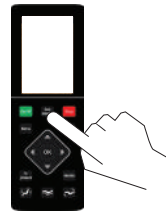

Step 3. Turn off the power

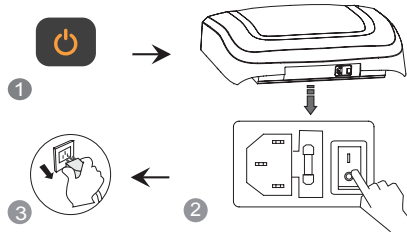

1. When the massage chair is On, press On/Off button to turn off the massage chair and it will restore automatically.
2. Turn off the power switch on the bottom of the back of chair after the rollers reach the storage position.
3. Unplug the power plug from the socket.



Warning

1. Before using, pull up the pillow, back cushion etc. to check if the PU material is broken, if there is damage, please stop using, unplug the massage chair, and ask for repairs.
2. Only plug into proper socket.



Attention

- Before sitting down, make sure there is nothing pinched between armrest, legrest, backrest and seat of the massage chair.
- Make sure the massage chair is in reset state before using.
- DO NOT stand on it when using the massage chair.

- **Legrest Up**
Press this button on controller to raise the legrest. Release the button to stop moving.



- **Legrest Down**
Press this button on the controller to lower the legrest. Release the button to stop moving.

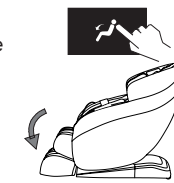

- **Backrest Down**
Press this button on controller to lower the backrest. Release this button to stop moving.

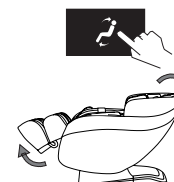

- **Backrest Up**
Press this button on controller to raise the backrest. Release this button to stop moving.

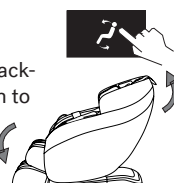

- **GravityFree™**
Press the "GravityFree" button, the backrest will go down and the legrest will raise up, and the massage chair goes into GravityFree™ position. Press the Button again, the backrest and legrest will stop moving. However, you can change the angles to keep a comfortable position all the time.

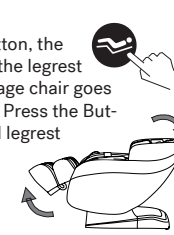

- **LegExtender™**
Legrest can extend or retract up to 9 inches.

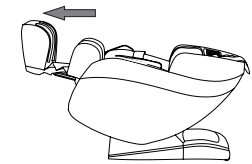

- **PalmSoothe™**
The armrest has built-in pulse pressure massage function, put your arm in the air bag when it is not inflating. It will slowly inflate, and massage your arm and hands.

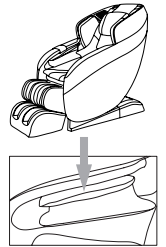

- **PressureRelief™**
An air pressure massage that can help alleviate the stress and strain in shoulders tired from daily activities.

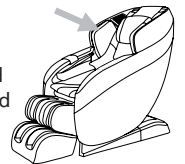

- **SoleRefresh™**
SoleRefresh™ delivers a foot roller massage.
- **CalfRelief™**
CalfRelief™ provides a calf air compression massage.

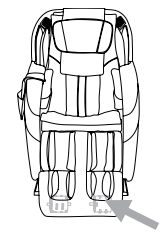

1. Please make sure the area is clear to avoid unexpected injuries or property loss.
2. When adjusting the backrest, be careful of the gap between the backrest and armrest.
3. When the legrest is moving, please DO NOT stand on or leave from the seat, DO NOT stop the legrest from moving in case of causing damage to the massage chair.
4. Please refer to control instruction for more details.

- 1 When returning the massage chair to the upright position, make sure there are no obstructions under the legrest.

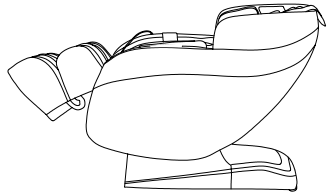

- 2 Return the backrest and legrest to their normal positions with the remote. (Or press the ON/Off to key to restore the massage chair to the normal position)

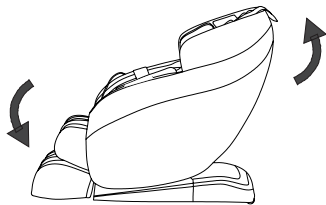
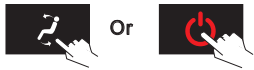

- 3 Put the controller back into the controller bag on the right armrest after the massage chair returns to the initial position.

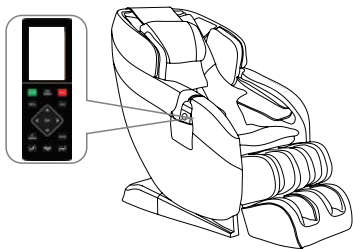

- 4 Switch off the power.

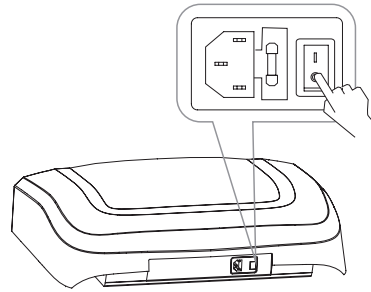

- 5 Unplug the massage chair from the socket.

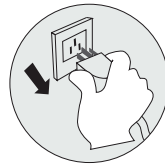

- 6 Clean the massage chair if necessary.



Attention!

- After using, press the ON/OFF to end the massage and wait for the massage chair to return to the initial position.
- Make sure to unplug the massage chair to avoid any unexpected injuries or damages.
- After using, turn off the power, unplug the electricity. Avoid moisture, dirt and aging of insulation to avoid damages.

Synthetic leather

● **General cleaning**

Clean with tidy, soft and dry cloth slightly.

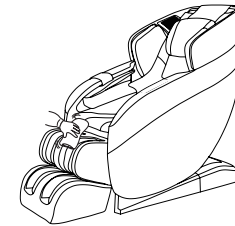

● **If leather is dirty**

1. Dip soft cloth into neutral detergent solution, squeeze it then clean the stain on the surface gently.
2. Wash cloth, squeeze it and wipe with detergent.

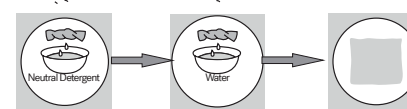

3. Clean it softly with dry cloth.
4. Allow to air dry (air blower is prohibited)

Cloth material

1. Dip cloth into weak neutral detergent, squeeze it and clean the material surface.

2. Brush the dirty parts with weak neutral detergent. (Avoid excessive brushing)

Excessive cleaning may cause damage to cloth material.

3. Wipe with water-dipped but squeezed cloth.

4. Allow to dry.



Plastic parts

1. Dip cloth into neutral detergent, squeeze it and clean.
2. Wipe with water-dipped but squeezed cloth.
3. Allow to dry.

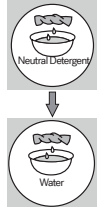

Clean the controller

1. Wipe with soft cloth after squeezing.
2. Allow to dry.



Remote control



About cleaning

- Before cleaning, unplug the electricity, DO NOT touch plug with wet hands.
- Make sure hands are dry when plugging to the socket.
- Failure to follow instructions may result in electric shock or burns.

Trouble	Possible reason	Troubleshooting
The massage chair does not power on.	Check if the control is on or not.	Open control switch.
	No massage function selected.	Choose massage function.
	Check whether the plug and socket are securely connected.	Make sure plug and socket are connected.
	Wire or plug has been damaged.	Please ask authorized retailer for service and repairs.
	The fuse burned out.	Replace fuse of same specification.
	Something is wrong with inner circuit.	Please ask an authorized retailer to check and repair.
Hear a beep sound inside massager while in use.	It is the sound of an air pump, motor or mechanical parts.	Normal sound, no need to pay attention to it.
Different height of the left roller and right roller.	Massage rollers work on shifts.	This is a normal occurrence.
Sound suddenly becomes much louder while working.	Check if it is due to extended runtime.	Turn off the power to let the massage chair rest for at least 30 minutes before the next use.
	Inner parts worn out due to extended usage is normal.	Please ask an authorized retailer to check and repair.
Massage function suddenly stops while working.	Suddenly powers down.	Check the power connection, remote, and the fuse.
	Preset massage time has been reached.	Turn off power to let the massage chair rest for at least 30 minutes before the next use.
Neither the backrest nor the legrest can be adjusted	Check if there are any obstacles; for safety reasons sometimes the massage chair may automatically stop working.	Remove the obstacles; turn off the power to let the massage chair rest for at least 30 minutes before next use.
The massage chair can't return to its original position.	Excessive operation - Preset massage time has been reached.	Please ask authorized retailer for service and repair.
Electric wire or plug gives out heat	It may be a work overload from excessive use.	Turn off the power to let the massage chair rest for at least 30 minutes before next use.
	Other abnormal case	Stop using and ask authorized retailer for service and repairs.



Note: If you are experiencing an issue not notated above, please contact your authorized retailer for assistance.

Name	Jacuzzi® Massage Chair	Power	180W
Model	JPro302XR™	Weight Limit	300 lbs
Input Voltage	240V~ 50Hz	Total Weight	238 lbs
Safety Design	Class I	Packing Size	45in × 31in × 48in (L W H)

Limited Lifetime Jacuzzi® Massage Chair Warranty

- Warranties are limited to the original purchaser, for residential use, and cover defects in material and workmanship. Units in commercial use are excluded from any warranty coverage whatsoever.
- Frame and massage rollers have a limited lifetime warranty.
- Motors, boards, console, belts, and power supply have a 5-year replacement warranty.
- All other parts, including but not limited to, non-electrical/mechanical attachments including head cover, back pad, arm covers, wheel castors, seat cover, and footrest cover material are warranted against defects in material and workmanship as of the time of delivery only.
- Consumer should register their product immediately upon purchase at <https://zenawakening.com/warranty-registration>, and keep original proof of purchase.
- See back cover for limitations and exclusions.

Consumer Warranty Limitations and Exclusions

- **IMPLIED WARRANTIES OF MERCHANTABILITY AND FITNESS FOR A PARTICULAR PURPOSE ARE DISCLAIMED ALTOGETHER OR TO THE FULLEST EXTENT ALLOWED BY LAW.** This limited warranty takes the place of all other warranties, express or implied, in fact or at law, including implied warranties of merchantability and fitness for a particular purpose. The coverages of this limited warranty are for defects in material or workmanship, and not damage caused by installation, unauthorized repairs or modifications, improper use of electrical/power supply, loss of power, dropped product, a malfunction or damage of an operating part from failure to provide manufacturer's recommended maintenance, transportation damage, theft, abuse, misuse, neglect, vandalism, environmental conditions (such as, fire, floods, rust, corrosion, sand, dirt, windstorm, hail, earthquake, or exposure to weather conditions), damage inflicted upon the massage chair by improper use, or accidental damage incurred by negligent use (i.e. surpassing the stated weight limit (300 lbs), remote damage from dropping on the ground, etc.). This limited warranty is void if the manufacturer or its designated representative determines that the massage chair has been subjected to damage or failure due to installation of aftermarket parts.
- **THE COMPANY WILL NOT BE RESPONSIBLE FOR INCIDENTAL OR CONSEQUENTIAL DAMAGES OR LOSSES ARISING FROM ANY CAUSE.** This exclusion applies even if the Company was advised in advance of the possibility of such damages. This limited warranty does not include labor, transportation, or other costs incurred in the removal and/or re-installation of the original unit and/or installation of a replacement unit; any costs relating to obtaining access for repair; or loss of use damage, including loss of sales, profit or business advantage of any kind under any circumstances. The liability of Company under this limited warranty, if any, shall not exceed the original amount paid for the product claimed to be defective. Dated proof of purchase is required for a warranty claim. These disclaimers shall be equally applicable to any service provided by the Company and its designated representatives.
- Warranties are non-transferable, are available only to the original purchaser, and shall be in lieu of any other warranty, express or implied, including but not limited to any implied warranty or merchantability or fitness for particular use. The sole liability of the manufacturer and distributor, Galaxy Health and Wellness, and the purchaser's exclusive remedy shall be for the repair, or at Galaxy Health and Wellness's option, for the replacement of the defective part. Notwithstanding the above, if replacement parts for defective materials are not available, the Company reserves the right to use replacement parts that may be different from the part(s) that accompanied the original massage chair, including but not limited to different in appearance, configuration, performance and/or structure, in lieu of repair or replacement.
- All Warranties begin on date of delivery. The Company is not responsible for any warranty representation or warranty implied by any third party, including but not limited to a selling dealer. There are no warranties applicable to Jacuzzi® Massage Chairs except as expressly stated herein or as implied by applicable state and federal laws. Jacuzzi® and its affiliates are not responsible for any warranty obligations. The only warranty is offered and administered by Galaxy Health and Wellness, and is for home applications only.
- The Company will repair or replace a defective part if the failure is of the nature or type covered by the warranty, the user informed the Company or its Representative of the nature of the problem during the warranty period, conclusive evidence is provided to the Company by the user proving that the failure occurred or was discovered within the warranty period, and the Company or its designated representative has been permitted to inspect the part and massage chair on which it was used during regular business hours within a reasonable time after the problem was reported by the user. In order to obtain warranty service, contact 1-866-234-7727. All replacement parts assume the remaining warranty period of the part(s) replaced. The Company's warranty obligation shall be discharged upon tender of replacement or repair. The customer's refusal to accept the tender terminates the Company's warranty obligation.
- The consumer may also have other rights that vary from state to state. Some states DO NOT allow limitations on how long an implied warranty lasts, disclaimer of certain warranties, or the exclusion or limitation of incidental or consequential damages, therefore some of the above limitations may not apply to the Consumer.