

Jacuzzi J-215

Specifications

Seating Capacity	2-3 Adults
Dimensions	69" x 80" x 33" (175 cm x 203 cm x 84 cm); For Complete Dimensions, See page 82
Dry Weight	517 lbs (235 kg)
Filled Weight (Spa Volume)	2,936 lbs (1,332 kg)
Filled Weight (Average Fill)	2,251 lbs (1,021 kg)
Water Capacity (Spa Volume) ...	290 US gallons (1,098 Liters)
Water Capacity (Average Fill) ...	205 US gallons (776 Liters)
Electronic Controls	Solid state electronic controls with LED readout, programmable temperature, filtration, and heat cycles
Pump 1	North America (60 Hz): 2-Speed, 2.5 HP brake, 1.5 HP continuous, 48 Frame Export (50 Hz): 2-Speed, 2.0 HP continuous on the completes
Circulation Pump	No
Total Jets	21
Seat A Jets	6 SLR Rotational
Seat B Jets	1 SLR Rotational, 8 SL Directional
Seat C Jets	4 SL3R Rotational
Footwell (D) Jets	2 SLR Rotational
Massage Selectors	None
Air Controls	1
Water Management System	One 50 ft ² filter cartridge on jets pump 1, ClearRay Active Oxygen® System Export (50 Hz): ClearRay® UV-C System
LED Lighting	LED Lighting System (Interior Surround); Standard Exterior Light
Cabinet Colors	Smoked, Charcoal
Acrylic Colors	Platinum, Silver Pearl, Monaco, Midnight, Porcelain (while quantities last)
Headrests	3
Heater:	North America (60 Hz): 120V 1kW or 240V 4.0 kW, High Flow Export (50 Hz): High Flow, 2.7 kW
Electrical Requirements:	North America (60 Hz): 120V@15A (GFCI cord) 240 VAC@30A or 40A Export (50 Hz): 220-240 VAC@1x16A, 1x32A or 2 out of 3-phase (see manual) or suitably rated circuit breaker to comply with local electrical codes. Certain countries may require dual power inputs; two GFCI RCD breakers are required for this configuration.
Warranty*	North America (60 Hz): 5 Years Shell, 3 Years Shell Surface, 3 Years Plumbing Component Leaks, 3 Years Equipment and Controls; 1 Year Cabinet, 1 Year Jets Export (50 Hz): 5 Years Shell, 3 Years Shell Surface, 3 Years Plumbing Component Leaks, 3 Years Equipment and Controls, 1 Year Cabinet, 1 Year Jets
Special Features (Optional)	SmartTub® Module
Audio System (Optional)	N/A

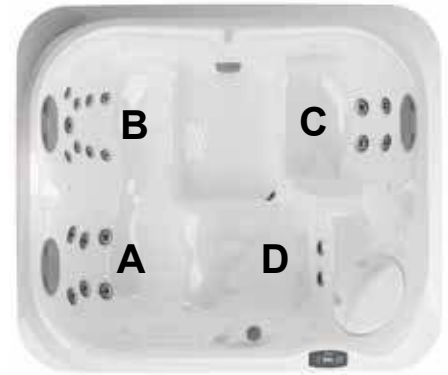

*(See Warranty Document for Specific Details)

Dimensions/Specifications are Subject to Change Without Notice

Jacuzzi J-215

Operation/Seat Depths



Air Control 1:
Opens/Closes
Air Inlet to Jets A

Jets are always on
when the Jets Pump 1
is running.

21 Total Jets

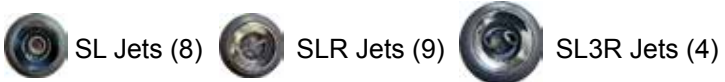

Spa Operation Subject to Change without Notice

Seat Depths

A = 25.13" (63.82 cm)

D = 18.00" (45.72 cm)

B = 26.00" (66.04 cm)

E = 25.75" (65.41 cm)

C = 23.50" (59.69 cm)

F = 27.63" (70.17 cm)

Listed dimensions
represent distance from
top of acrylic to lowest
point in seat. Tolerance
 $\pm 0.5"$ (1.27 cm).

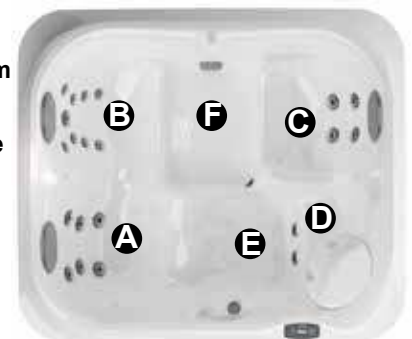

Dimensions/Specifications are Subject to Change Without Notice

Jacuzzi J-215

Dimensions

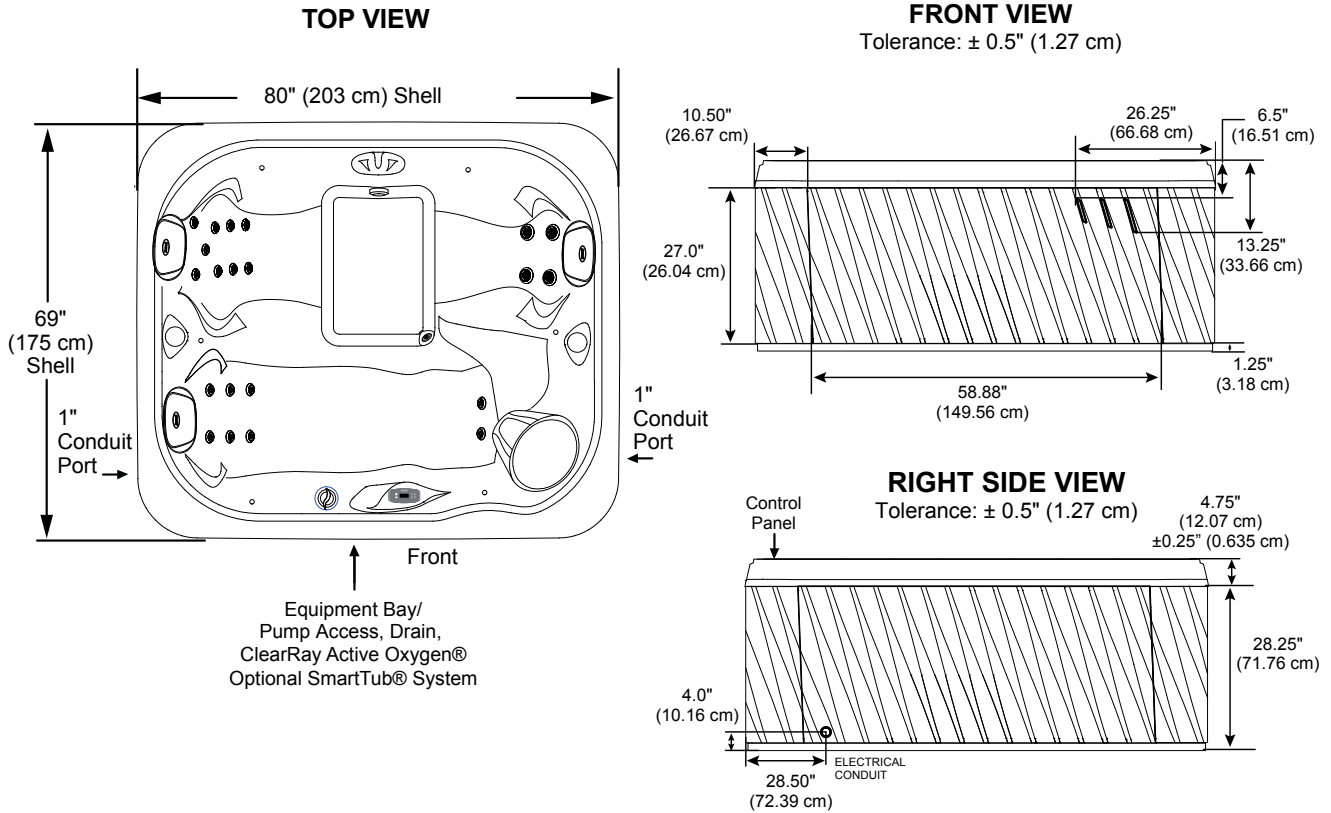

IMPORTANT! Always measure each hot tub for exact dimensions BEFORE designing its foundational support and/or decking.

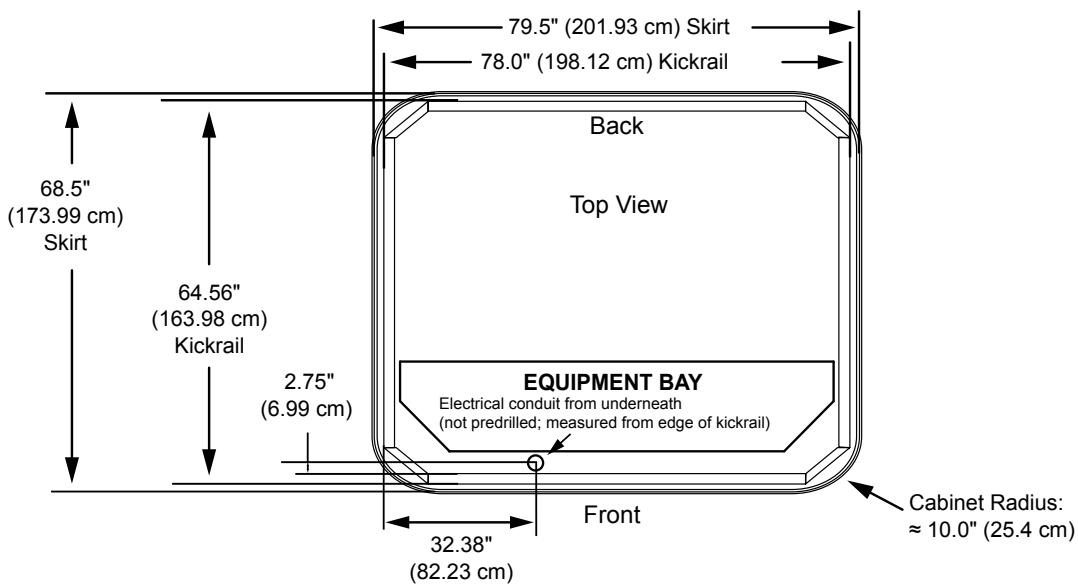

Dimensions/specifications subject to change without notice. Tolerance: ± 0.5" (1.27 cm)

Dimensions/specifications subject to change without notice. Tolerance ±0.5" (1.27 cm)